



*The Professional Choice*

# Bladder Accumulator



# General

Olaer, pioneer of high pressure equipment, was founded in 1938 by Jean Mercier. Using his experience, passion for research and extensive knowledge of hydraulics in the demanding field of aeronautics, Mr. Mercier engineered the first gas loaded bladder accumulator. This has led to Olaer becoming the indisputable international leader in this field.

Solutions developed by Olaer are used in a large number of industrial sectors: aeronautics, chemistry, defence weaponry, mining, railway construction, formula 1, machine tools, agriculture, oil and gas, metallurgy, renewable energies, etc.

This variety of applications requires extensive knowledge of the products and their major components, particularly the bladder. In order to reinforce its position, Olaer is the co-owner of its main bladder supplier.



For either a standard application or designing solutions for a specific requirement, Olaer engineers have the experience in elastomers and knowledge of the latest technological developments in metal and composite shells. This allows Olaer to propose reduced weight accumulators and other design innovations.

We provide cost effective solutions based upon our customer's needs. Olaer utilizes comprehensive tools and resources including an applications database, CAD/CAM, finite element analysis, reliability studies and simulation software which enable us to optimize design and performance.



## Operation

The OLAER gas loaded accumulator is an essential component for the optimum operation of a hydraulic circuit. In hydraulic circuits, the accumulator enables:

- An energy reserve which is instantaneously available to the system
- Compensation of pressure fluctuations and spikes.
- Pump pulsation dampening

## Advantages/Your benefits

The gas loaded bladder accumulators provide major advantages in terms of the energy output of the device and maintenance of the installation:

- **Reduction in working costs**
  - Reduces installed electrical power
  - Significant energy saving
- **Increase lifetime of equipment**
  - Reduces pulsations
  - Protects against pressure peaks
- **Reduction in maintenance cost**
  - Reduces wear of hydraulic components
  - Requires minimum maintenance of the installation

## Operating principle

Operation of the OLAER gas loaded bladder accumulator is based on the considerable difference in compressibility between a gas and a liquid, enabling a large quantity of energy to be stored in an extremely compact form. This enables a liquid under pressure to be accumulated, stored and recovered at any time.

Its special design allows the bladder (the strategic component) to compress the gas and usually form into three lobes in order for the accumulator to store, then to deliver the fluid under pressure, as required.

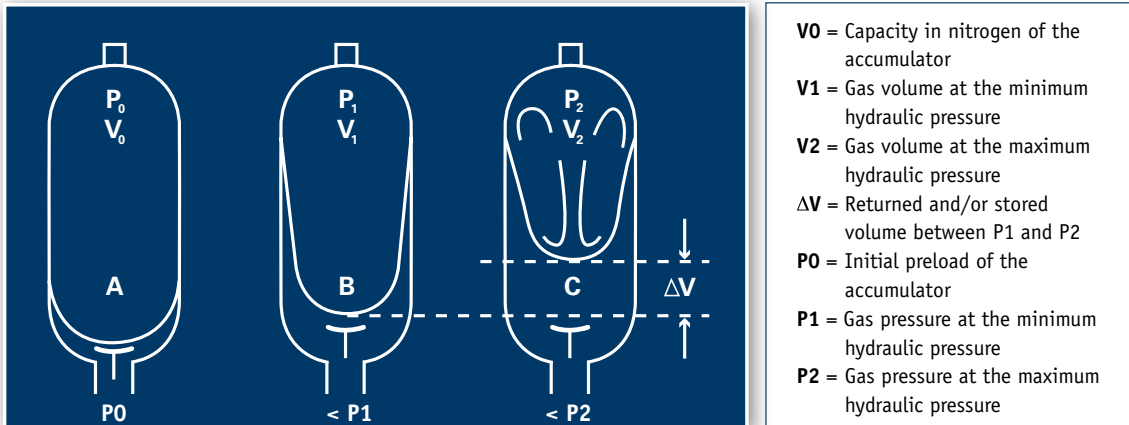

**A** - Bladder in the precharge position, which means that the accumulator only contains nitrogen. The anti-extrusion system closes the hydraulic orifice which prevents the destruction of the bladder. In low pressure accumulators the bladder rests against the grid.

**B** - Position at the minimum operating pressure. There must be a certain amount of fluid between the bladder and the hydraulic orifice, such that the anti-extrusion system does not close the hydraulic orifice.

**C** - Position at the maximum operating pressure. The volume difference between the minimum and maximum positions of the operating pressures represents the working fluid quantity.

## Technical Characteristics

The accumulator comprises of a pressure vessel, a rubber bladder and an anti-extrusion system.

- Shell material options include alloyed steel, stainless steel, aluminium, titanium and composites.
- Various bladder materials available which are compatible with a range of fluids and temperatures.
- Different anti-extrusion systems can be used for specific applications (fluidport assembly for high pressure, grid for low pressure, or button).

Taking into account the different needs of various applications, Olaer proposes different protections external and/or internal: Bare metal, nickel plating, epoxy paint, PTFE, Rilsan® and phenolic coating. This extensive range enables us to offer accumulators operating from  $-50$  to  $+150^\circ\text{C}$  with pressures of up to 1500 Bar and capacities of up to 570 litres.

As the market leader in bladder type accumulators, Olaer has participated in the development of the EN 14359:2006 standard, which specifies the material, design, manufacturing, tests, safety devices and documentation (including the instruction manual), for pressure accumulators and gas bottles for hydraulic applications.



### Top Repairable accumulators

This accumulator type can be serviced from both the fluid side or the gas side. The design utilizes many standard accumulator parts, but is unique in that it does not have to be removed from the system in order to change the bladder. This can in many applications be a great advantage. The gas end adapter mechanically locks to prevent disassembly under pressure.



### High flow bladder accumulators

Olaer has several versions of bladder accumulators for high flow applications, depending on how high the flow requirements will be.

The first step up from our standard is a high flow version with a 2" fluid port, where the internal geometrics of the port body and poppet valve are specifically designed for that purpose. The next step is a 2 1/2" fluid port which will provide even higher flows. For ultimate demands a 4" fluid port can also be proposed.

Please note that the last two solutions require shells with larger openings, and are not always available in all shell sizes. Olaer can tailor make the different parts to suit your technical needs.



### Transfer barriers

This range is a special adaptation of the bladder accumulator, with a pipe connected to the gas side of the accumulator. The most common application is to use the transfer accumulator in energy storage applications. The accumulator is connected to an additional volume of nitrogen, for example a gas cylinder. This increases the total volume of the system. Such systems are often mounted together in a battery or rack type installation.

A Transfer Barrier Accumulator can also be used to separate two liquids or a gas and liquid. It is usually a question of separating two liquids, one of which is aggressive or contaminated. To limit the number of parts in contact with the aggressive liquid, it is common practice to put the aggressive fluid inside the bladder and therefore connect on what is normally the gas side.

Pending of the accumulator volume, the displaced volume must not exceed 80% of the volume of the transfer accumulator.

# How to size?

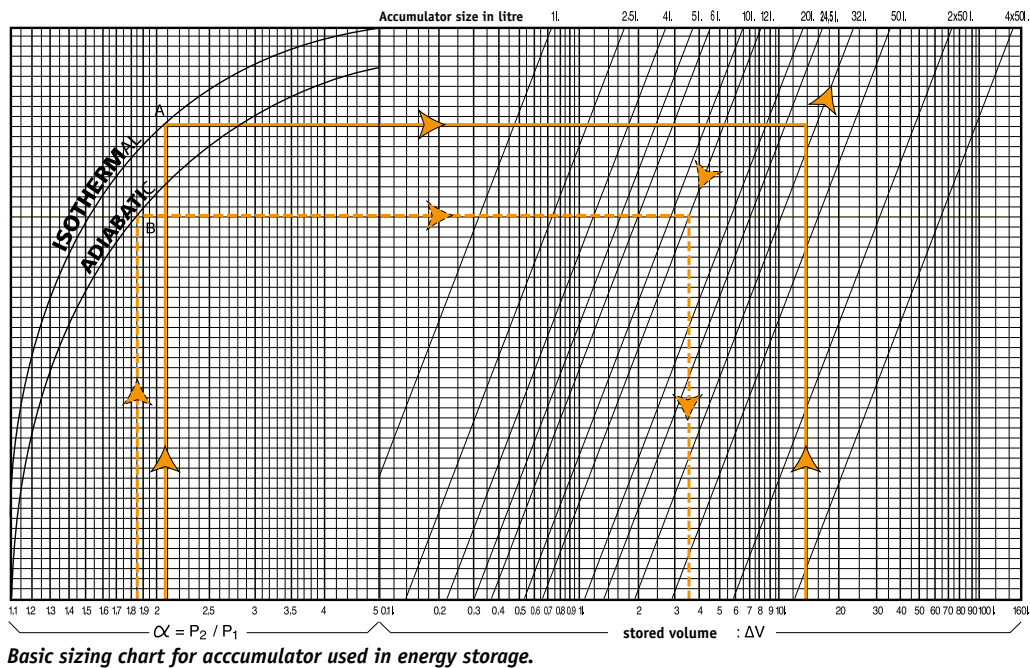

Olaer has developed very sophisticated simulation software to optimize accumulator sizing recommendations. The behaviour of accumulators used in applications such as pulsation dampening, surge alleviation, thermal expansion and energy storage can be simulated. Our software is available on CD-Rom and can be downloaded from our website. You may also contact your local Olaer office for sizing assistance.



The above graph is useful to estimate the size of an accumulator used to store or deliver a specific volume of liquid within a given pressure range. These curves are the graphic representation of an adiabatic\* cycle (fast cycling rate -  $N = 1.4$  perfect gas assumption) or isothermal\* cycle for an accumulator working at 20°C with a precharge  $P_0 = 0,9 P_1$ .

They do not take into consideration the real gas compression correction factor, the real adiabatic coefficient and the polytropic rate of the application. Depending on the application data, the influence of these factors may be significant, and require that some calculations adjustments be made. The Olaer simulation software takes all these factors into account.

**Sizing of an accumulator** to be installed in the following example conditions:

$P_2$  : Maximum available pressure : 210 Bar

$P_1$  : Minimum working pressure : 100 Bar

$P_0$  : Nitrogen precharge : 90 Bar

Condition : Isothermal (No temperature variation)

**A/Compression ratio**  $\alpha = P_2/P_1 = 210/100 = 2,1$

**B/From the value 2,1** on the  $\alpha$  axis, draw a vertical line that intersects the isothermal reference curve in A.

**C/From the value 14** on the  $\Delta V$  axis, draw a vertical line. The intersection point of this line with the horizontal line meeting A indicates a required accumulator size of 32 L.

**Calculation of the volume drawn off from an accumulator.**

Accumulator size = 12 L

$P_2 = 185$  Bar;  $P_1 = 100$  Bar;

$P_0 = 90$  Bar; Adiabatic condition

$\alpha = P_2/P_1 = 185/100 = 1,85$

## \*Reminder

**Isothermal:** The transformation is said to be isothermal when the compression or expansion of the gas occurs at a rate slow enough to allow a good thermal exchange, allowing the gas to remain at constant temperature.

**Adiabatic:** The transformation is said to be adiabatic when the cycle is quick and does not allow a temperature exchange with the ambient media.

## Different elastomer options

Olaer can offer many different elastomer options depending on the application where you will use our product. Two of the most important parameters for deciding the rubber compound to be used is:

1. The minimum and maximum operating temperature to be used in the system.
2. The fluid type in the system.

The most common bladder for hydraulic systems with mineral oil is Nitrile (also called NBR or Buna). A host of other rubbers such as Butyl, Hydrin®, Viton® or EPDM and more are available. Please contact your local Olaer office for your specific application.

Also, be sure to note that even if you change the bladder to one with particularly high or low temperature characteristics, the pressure vessel does not change. It also has temperature limitations on the pressure vessel approval.

## Regulations

Olaer designs and manufactures gas loaded accumulators for use in all countries, as well as other industry specific approvals including oil & gas, naval and nuclear. The main regulations in force are PED for European market, ASME for US market and SELO for Chinese market.

As a service, Olaer can recommend the appropriate regulations applicable if customers know the country where the accumulator will be installed.

When operating in dangerous and explosive environments, Olaer has designed an ATEX Group 2 cat. 2 and 3 range of accumulators.

Some of these regulations call for the use of safety devices to protect the accumulator against over pressure. Solutions may include hydraulic safety blocks, relief valve, gas side safety devices such as burst discs and fuse plugs.

Olaer has designed and proposed a complete range of safety devices suitable for the applicable regulations.

To meet the needs of our customers, Olaer can supply accumulators with multiple approvals.

With regard to the environment concern Olaer is attentive to put on market products which comply with reach regulation.

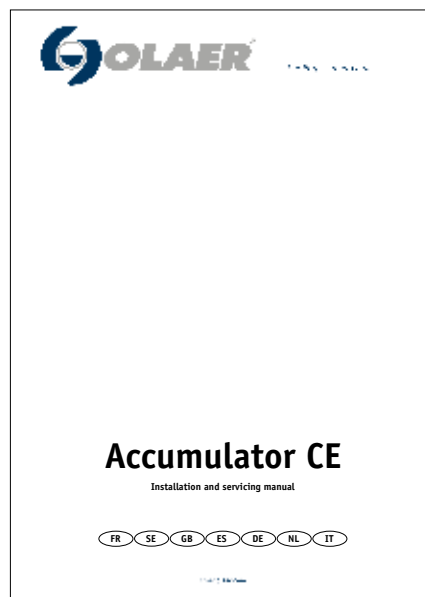

# Installation

**Position:** Preferably vertical (liquid connection downwards) to horizontal, depending upon application. If the accumulator is installed in any position other than vertical with fluid port down, contact Olaer. The accumulator could have reduced volumetric efficiency and Olaer can help you to take these factors into account.

**Mounting:** A 200mm clearance is required above the accumulator to allow for gas charging. Each accumulator is delivered with a user instructions leaflet.

## Gas filling

For safety reasons, use only pure nitrogen, minimum 99.8% volume. In most of the cases the pre-charge pressure is between 0,9 P1 and 0,25 P2. Your local Olaer office can calculate the correct pre-charge pressure for your application. Olaer offers a range of devices for checking nitrogen pressure as well as pre-charging accumulators.

*Please note that various adaptors are required to interface with different accumulator filling valves and nitrogen (N<sub>2</sub>) cylinder connections throughout the world.*

## Labeling and Marking

Important identification on an accumulator:



1. Designation of the accumulator
2. Manufacturer
3. CE marking and/or other pressure vessel approvals

The part number defines the accumulator and the material construction.

Information contained on the labeling/manufacturer's plate:

- Olaer logo
- Product description
- Date or year of manufacture
- Reference information of the accumulator
- Allowable temperature range of the accumulator

Additional information on certain models:

- Warning messages and safety instructions ("Danger", "Use nitrogen only" or similar message)
- Maximum inflation pressure P0 max in bar
- Allowable pressure amplitude  $\Delta P$  max in bar
- Fluid group (1 or 2 according to the Directive 97/23/EC)
- Total dry mass in kilogram

## Maximum allowable operating pressure

The maximum pressure (PS) is indicated on the accumulator. Check that the maximum allowable pressure is greater than that of the hydraulic system. For any other pressure, you will have to contact Olaer.

## Maximum allowable operating temperature

The temperature range (TS) is indicated on the accumulator. Check that the allowable temperature range covers the operating temperatures (environment and hydraulic fluid temperatures). For any other temperature, you will have to contact Olaer.

# Applications

## The reduction of installed power

The system requirement (1) is not always equivalent to the flow of the pump (2).

During the periods when these requirements are less than the flow, the surplus can be stored in an accumulator (3). If the need level rises (4), the pressure in the system drops. This causes the instantaneous release of the liquid stored (5) which thus provides for the flow required.

Advantages:

- Lower pump power consequently reduced operating costs.
- Absorption of all pressure variations consequently an increase in the life of the components.

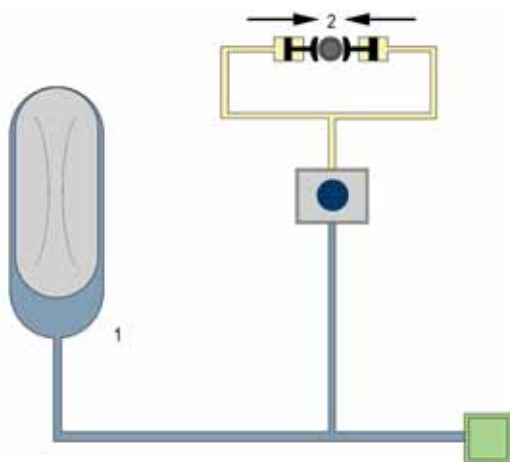
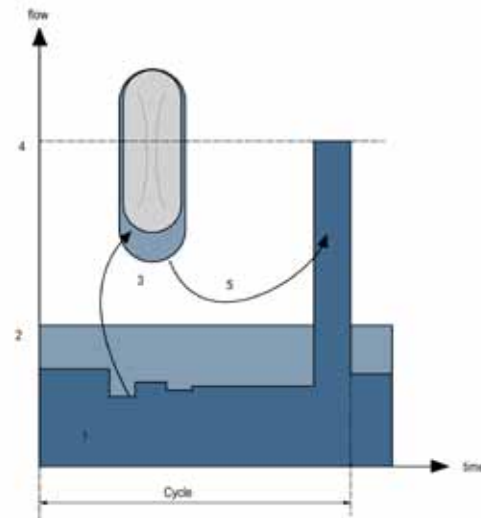

## Reserve emergency power and safety

The energy retained in a gas loaded accumulator can provide instant and repetitive operations at any time. Examples of this are activating backup systems, safety braking or opening doors.

Example of an emergency brake system for a ski lift:

The accumulator is filled ahead of time with liquid under pressure (1). If necessary, a control mechanism releases this liquid under pressure, which presses the jaws of the brake against the suspension cable (2). In other cases, the accumulator is supplied with pressure by the system's pump and acts only in the event of pump failure. Application examples: Emergency and safety systems for closing doors, valves, etc.

## Hydraulic spring

Gas loaded accumulators have successfully been used on mechanical crusher or press plates. In crushers, the space (E) between the cone and the cover determines grain size. Hydraulic accumulators adjust this space during the crushing operation while at the same time allowing the cover to lift up quickly, if there was an uncrushable object mixed in with the product. In this case, the accumulators are acting both as an active component and a safety component, thus increasing product life and reducing space consumption.

Application examples: Press pressure plates, ploughs and hydraulic suspensions.

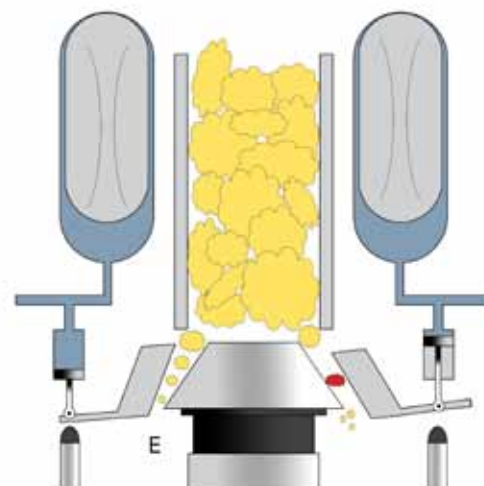

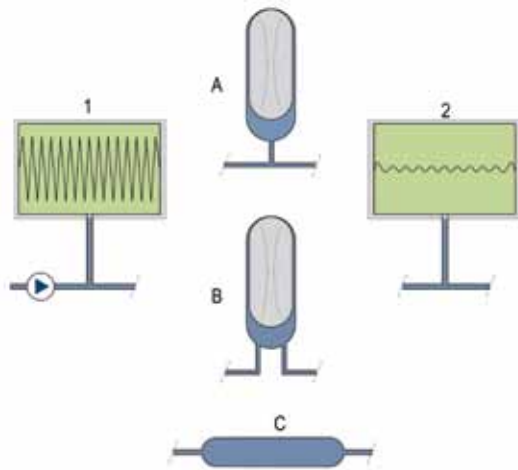

## Pulsation dampening

Depending on the volumetric characteristics and frequency of a pump, an accumulator, silencer or pulsetone can dampen the pulsations, thereby reducing fatigue of components and achieve noise attenuation of 20 dB. In hydraulic installations, pumps generate pulses producing fatigue in components and irregularity in flow (1). The accumulator (B) or the pulse-tone accumulator (A) absorbs these pulses and the flow is regulated (2). The life of the components increases.

Applications : Metering pumps

For very high frequency pulse rates, the hydraulic muffler can be used (C). Application example: High frequency hydraulic pumps.

## Thermal expansion compensators

The installation of an accumulator compensates for the change in volume caused by temperature differences, thus limiting over pressurization inside a closed system.

In a system subjected to large temperature differences (1 = heater, 2 = heat exchanger), the internal liquid is subjected to variations in volume. In this case, the accumulator acts for both applications. by temporarily storing the expanded liquid, the accumulator (3), compensates for the variation in volume, limiting the pressure variations in the system. This prevents potential system failure and increases the life of the components.

Application examples: Thermal power plants, pipelines and test benches.

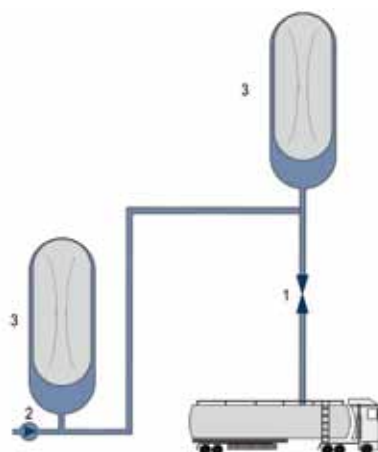
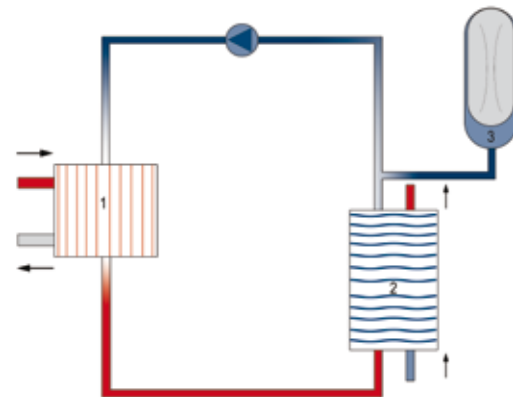

## Other Applications

Above, and on the previous pages, we have shown some basic diagrammes on how installing an accumulator can improve your system. Many more examples are available upon request.

## Surge control

Sudden modifications of the flow in a hydraulic system, following the closing of a valve (1) or the stopping or starting of a pump (2), can generate pressures waves which travel through the pipe lines causing water hammer. The accumulator (3) converts these wave oscillations to oscillations of the liquid mass which it absorbs, consequently bringing the pressure surge back to an acceptable value.

Application examples: Water and fuel distribution, loading and unloading stations for liquids.

Contact your local Olaer Company in order to optimize and improve your system using accumulators. Whether it is making it more efficient, work faster, smoother or just help remove any problems you have running your system.

# Special Applications



From the fighter Dewoitine 520 in 1936 to the Airbus A380, Olaer has always developed high technology and light composite reinforced solutions for the storage of onboard hydraulic energy for plane and helicopter applications.

Olaer accumulators provide reliability with high quality in the most extreme service conditions where the life of people are depending on reliable and consistent operation of the products.



In the daily improvement development area, Olaer capabilities in application are helping the biggest players of formula One and racing, providing them very light and safe technical solutions.

Olaer has installed accumulators in power plants (hydraulic, thermal and nuclear), supplying safe and reliable solutions in energy storage and pulsation dampening while meeting the most exigent specifications.



# Peripherals



## Burst disc assembly

All gas loaded accumulators are gas pressure vessels. Depending on the regulation, a burst disc could be fitted to protect the accumulator, in addition to the relief valve protecting the hydraulic system. All Olaer accumulators can be supplied with our burst discs.

## Clamps and brackets

A complete range of standard clamps and brackets both in carbon and stainless steel are available.

## Nitrogen precharge equipment

The universal charging set VGU fits all possible accumulator models supplied by Olaer and most other manufacturers of accumulators. In addition there are simpler versions available that are manufactured specifically for each type of gas valve.

## Safety Blocks

Olaer has developed a complete range of safety blocks (sizes NG 10 to 50) to answer all standard and special applications. The blocks are used for isolation and pressure relief and contain a safety valve.

The blocks are in conformity with the European Directive on the equipment under pressure (97/23 EC). The safety blocks are designed as compact units, with all the components necessary for the correct operation of a hydraulic system equipped with gas loaded accumulators.

More detailed information about the sizes, the internal valves, etc. are available in our specific data sheet for safety blocks. Special, custom made blocks are also available if your needs fall outside our standard range.



## Cleanliness

More and more hydraulic systems have very high demands on component's cleanliness when delivered, either because of very critical components and systems such as aircraft, or installations where unscheduled or even scheduled maintenance shut-downs are costly.

We see more and more systems where this is demanded. Olaer routinely delivers accumulators according to ISO4406, down to 15/13/10. We can also deliver to other standards. Examples of this can be aerospace applications, wind turbines, offshore/subsea oil & gas installations.



- in Fluid Energy Management

# Global perspective

*and local entrepreneurial flair*



Olaer is a global player specialising in innovative, efficient system solutions for temperature optimisation and energy storage. Olaer develops, manufactures and markets products and systems for a number of different sectors, e.g. the aircraft, engineering, steel and mining industries, as well as for sectors such as oil and gas, contracting and transport, farming and forestry, renewable energy, etc.

All over the world, our products operate in the most diverse environments and applications. One constantly

repeated demand in the market is for optimal energy storage and temperature optimisation. We work at a local level with a whole world as our workplace – local entrepreneurial flair and a global perspective go hand in hand.

Our local presence, long experience and a wealth of knowledge combine with our cutting-edge expertise to give you the best possible conditions for making a professional choice.